



City of Belle Plaine | Building Inspections

218 Meridian Street North | Belle Plaine, MN | 952-873-5553

RE-ROOFING CODE REQUIREMENTS

For single family residential structures

NOTE: Two inspections: Half-way and Final. The Inspector needs to see the ice and water barrier. The best time is during the half-way point of the roofing job. Photos are accepted - email to inspections@belleplaimn.gov. It is the applicant's responsibility to schedule inspections.

1. All valleys, saddles, side wall connections & where the lower portion of a sloped roof stops within the plane of an intersecting wall cladding, must have flashings. Existing vent flashing, metal edgings, drain outlets, collars & metal counter-flashings shall not be reinstalled where rusted, damaged or deteriorated.
2. One layer of self-adhering polymer modified bitumen sheet (Ice & Water barrier) or equivalent shall be applied from the eaves to a line 24 inches inside the exterior wall line. Exception – Detached accessory structures that contain no conditioned space.
3. "Fasteners for asphalt shingles shall be galvanized steel, stainless steel, aluminum or copper roofing NAILS, minimum 12 gage shank with a minimum 3/8 inch diameter head, of a length to penetrate through the roofing materials and a minimum of 3/4 inch into the roof sheathing."
4. Attic Ventilation (roof vents).
 - a. 1/300 of roof area.
 - b. 50% - 80% to be near the roof ridge.
 - c. The balance to be provided by eave or cornice vents. 1/150 of roof area if no openings provided in eaves or cornices.
5. Post permit card on construction site visible from the street.

**The State of Minnesota requires that all residential building contractors, remodelers and roofers obtain a state license unless they qualify for a specific exemption from the licensing requirements. Any person claiming an exemption must provide a copy of a Certificate of Exemption from the Department of Labor & Industry to the City before a permit can be issued.*

**To determine whether a particular contractor is required to be licensed or to check on the licensing status of individual contractors, please call the Minnesota Department of Labor & Industry, Residential Building Contractors Unit at 651-284-5065.*

If you have any questions or need to schedule an inspection, call City Hall at 952-873-5553.

MID-ROOF INSPECTION

The City of Belle Plaine requires a mid-roof inspection. The ideal time to have this inspection is when the shingles have been removed and the required ice and water has been installed. The city recognizes that the timing of this inspection can be difficult to predict, therefore in an effort to eliminate any delays in your project pictures will be allowed. To aid the inspector in determining code compliance, refer to the attached picture list.

If you are a homeowner or a contractor wishing to do a project that is not during normal business hours, the City of Belle Plaine with prior approval of the Building Official will allow pictures as well.

If you have any questions contact the Building Official at 952-873-5655. Email photos to **inspections@belleplianemn.gov**.

1. Pictures of the front of the home with the address number visible.
2. Pictures of the decking include all planes or the roof (show deck board spacing where applicable).
3. Pictures of chimneys, or other unusual features and their flashings.
4. Pictures of any repairs made to decking or other appurtenances.
5. Pictures of the required ice and water protection.
6. Pictures of the Underlayment.
7. Pictures of step flashing.
8. Pictures of the required ventilation.
9. Pictures of the completed roof.

Ice protection underlayment

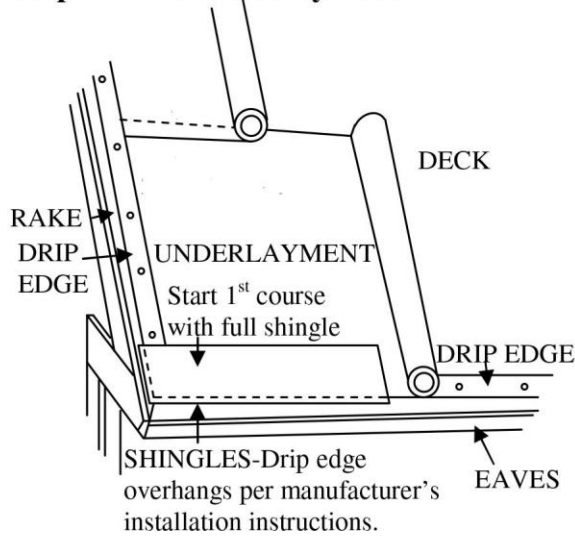

- When installing underlayment, care should be taken to install it wrinkle free. The underlayment should be installed over the eave drip edge and under the rake drip edge.
- Underlayment layers shall overlap 2 inches horizontally and 4 inches vertically.

Shingle application

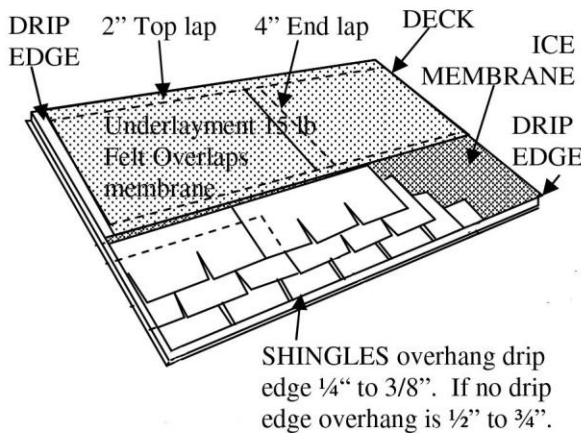

Sidewall flashing (26 Gauge)

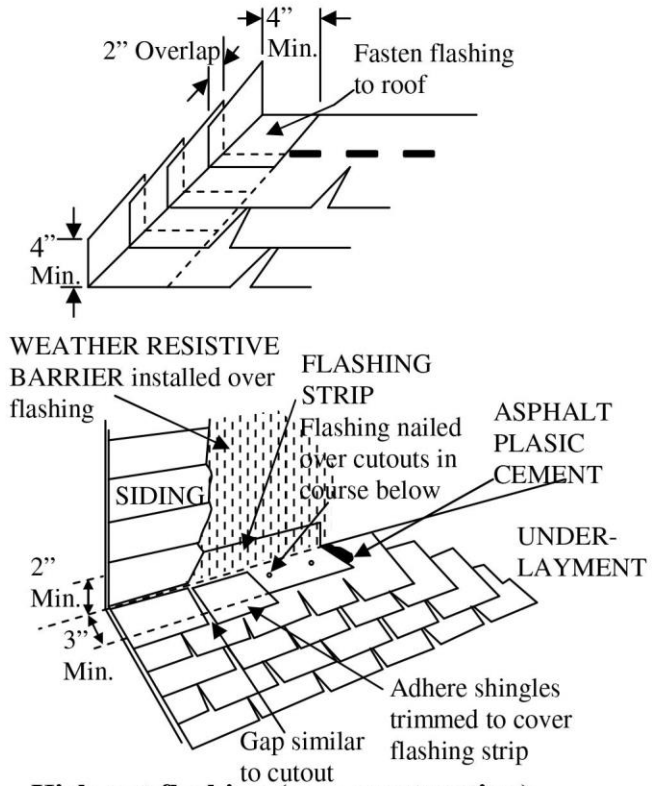

Kick-out flashing (new construction)

